

INSTRUCTION HANDBOOK

Minigraf 44



Alfamacchine

Via dell'Artigiano, 12 - 47100 Forlì - Italy
Tel. +39-0543-482711 - Fax +39-0543-480770
info@alfamacchine.com - www.alfamacchine.com

INDEX

1. GENERAL INFORMATION	3	4.6 CONNECTIONS	9
1.1 PRODUCER	3	4.6.1 PNEUMATIC CONNECTION	9
1.2 ASSISTANCE CENTERS	3	4.7 PRELIMINARY CONTROLS	10
1.3 CERTIFICATION	3	4.8 MACHINE ARRANGEMENT	10
1.4 WARRANTY	3	4.8.1 V-Nails magazine loading	10
1.5 PRE-ARRANGEMENTS CHARGED TO THE CUSTOMER	3	4.8.2 V-nail guide head replacement to change V-nails size	11
1.6 HANDBOOK STRUCTURE	3	4.9 ADJUSTMENTS	12
1.6.1 Object and contents	3	4.9.1 Setting stops for V-nails positioning	12
1.6.2 Utilizers	3	4.9.2 Vertical clamp adjustment	12
1.6.3 Preservation	3	4.9.3 Horizontal clamp adjustment	12
1.6.4 Symbols utilized	4	4.9.4 Fences adjustment	13
2. MACHINE DESCRIPTION	5	4.9.5 Protective shield adjustment	13
2.1 WORKING PRINCIPLE	5	4.9.6 Working pressure	14
2.2 MAIN COMPONENTS	5	4.10 CHECKING OPERATIONS TO BE EFFECTED BEFORE WORKING START	14
2.3 MACHINE STRUCTURE	5	5. FUNCTIONING	15
2.4 DIMENSIONS	5	5.1 OPERATORS	15
2.5 SURROUNDING CONDITIONS	5	5.2 FUNCTIONING DESCRIPTION	15
2.6 LIGHTING	5	5.3 TIPS FOR PERFECT JUNCTIONS	16
2.7 VIBRATIONS	5	5.4 MACHINE STOP	16
2.8 NOISE EMISSIONS	5	5.5 MACHINE REINSTATEMENT	16
2.9 TECHNICAL DATA	6	5.6 PUTTING OUT OF SERVICE	16
2.10 STANDARD EQUIPMENT	6	6. MAINTENANCE	16
2.10.1 Standard accessories	6	6.1 STATE OF MAINTENANCE	16
2.10.2 Upgrading and implementing of mechanical parts	6	6.2 MACHINE ISOLATION	16
2.10.3 Optional accessories	6	6.3 SPECIAL CAUTIONS	16
2.10.4 Customized optional accessories	6	6.4 CLEANING	16
2.11 ELECTROMAGNETIC AMBIENT	6	6.5 LUBRICATION	17
3. SAFETY	7	6.6 ORDINARY MAINTENANCE	17
3.1 GENERAL WARNINGS	7	6.7 EXTRAORDINARY MAINTENANCE	17
3.2 SCHEDULED USE	7	7. DIAGNOSTIC	18
3.3 INADVISABLE USE	7	7.1 SAFETY WARNINGS	18
3.4 DANGEROUS AREAS	7	7.2 TROUBLESHOOTING	18
3.5 PROTECTION DEVICES	7	7.3 REQUEST OF ASSISTANCE	19
3.6 STOP FUNCTIONS	7	8. SPARE PARTS	20
3.7 SAFE WORKING PROCEDURES	7	8.1 SPARE PARTS LIST	20
3.8 RESIDUAL RISKS	8	8.2 SPARE PARTS ORDERING	20
3.9 PLATES	8	9 DEMOLITION	20
4. INSTALLATION	8	9.1 DEMOLITION	20
4.1 SHIPPING AND HANDLING	8	10. ATTACHMENTS	20
4.2 STORAGE	9	10.1 DECLARATIONS	20
4.3 PRELIMINARY ARRANGEMENTS	9	10.2 SCHEMES	20
4.4 UNPACKING	9		
4.5 MACHINE POSITIONING (floor stand version)	9		



* This machine is equipped with a frontal safety guard as standard equipment to comply with CE regulations for the EUROPEAN MARKET.
It can be supplied for other markets only on request with an additional charge.

1. GENERAL INFORMATION

1.1 PRODUCER

The firm Alfamacchine can boast more than 10 years of experience in the construction of Woodworking Machines. It is the acquired technological know-how, developed during years of researches in strict touch with manufacturing department and international commercialization the best warranty that Alfamacchine can grant to its customers.

TEL +39-0543-482711	FAX +39-0543-480770
---------------------	---------------------

1.2 ASSISTANCE CENTERS

Alfamacchine is represented both in Italy and Europe by a numerous and prepared sales organization. Contact directly our firm to the over impressed numbers to have the indications concerning the local Assistance organization. For every need regarding Use, Maintenance or Request of Spare Parts, the Customer is pleased to address to the authorized service centers or directly to Alfamacchine, specifying the machine identification data impressed on the plate.



1.3 CERTIFICATION

The machine is produced in conformity to the pertinent European Community Norms in force at the moment of its introduction on the market.

1.4 WARRANTY

The Alfamacchine's products are constructed to have a long duration and are tested one by one.

If, in spite of this, would occur any damages or malfunctioning, the replacement of defective parts is warranted (counting from the date written on the delivery bill) for a period of:

- 24 months for mechanical components
- 12 months for pneumatic part

The driver blade is tested for about 1.000.000 working cycles. The Warranty does not include the sending of technical staff. The repair interventions will be effected at Alfamacchine's and the freight of shipment will be entirely charged to the Customer.

The warranty does not cover the damages caused by a not appropriate use of the machine or not corresponding to the instructions described in this handbook.

The warranty decays in case of unauthorized modifications or because of accidental damages or tampering effected by unqualified personnel.

The warranty decays also in case of using of V-nails different from original Alfamacchine's ones.

To take advantage of warranty services is necessary, at the moment of goods reception, to fill up completely the form attached in 3 copies, and send it back as soon as possible to Alfamacchine.

The remaining copies will be attached to the machine documentation.

The warranty will be valid after the Alfamacchine's recording.

1.5 PRE-ARRANGEMENTS CHARGED TO THE CUSTOMER

It is a customer duty, on times agreed with the producer, to execute what is indicated in our documentation.

Are normally charged to the customer:

- Premises predisposition, included building works and/or canalization eventually requested
- Pneumatic supply of compressed air (see the paragraph 4.5)

1.6 HANDBOOK STRUCTURE

The customer must pay an extreme attention to the indications reported on this handbook, because the proper Pre-Arrangement, Installation and Use of the Machine, constitute the basis of a correct customer-manufacturer relationship.

1.6.1 Object and contents

This handbook aim is to provide to the customer all necessaries information so that, besides the proper use of the machine, He would be able to run it in complete autonomy and safety. The handbook contains information concerning the technical aspects, machine working and standstill, maintenance, spare parts and safety. Before making any operation on the machine, the qualified technicians and operators must read carefully this handbook instructions. In case of doubt about correct interpretation of a.m. instructions, ask to Alfamacchine the explanations requested.

1.6.2 Utilizers

This handbook is made both for operators and technicians authorized to the machine maintenance.

The operators can not execute operations reserved to the maintainers or to the qualified technicians.







The producer does not answer of damages derived from not-observance of this prohibition

1.6.3 Preservation

The instruction handbook must be kept very closed to the machine, into a special container protected from liquids and whatever could compromise its legibility

Minigraf 44

1.6.4 Symbols utilized

 P...	DANGER	it indicates a danger with a mortal risk for the operator
 A...	WARNING	It indicates a warning or a note about key functions or useful information. Pay the maximum attention to the paragraph marked with this symbol.
 O...	OBSERVATION	is requested to take a measurement data, to check a signal,....
 I...	INQUIRY	the utilizer is requested to check the proper positioning of any element of the machine, before operating a certain command
 C...	EXAMINATION	It's necessary to consult the handbook before effecting a certain operation
 R...	ADJUSTMENT	in case of strange working and/or anomalies, can be requested a certain mechanical adjustment and/or electrical setting

2. MACHINE DESCRIPTION

2.1 WORKING PRINCIPLE

The Minigraf 44 is a pneumatic frame assembling machine particularly suitable with large sized frames.

The machine is equipped with a V-nails driver blade mounted on a movable carriage which, manually shifted by the operator allows the quick insertion of V-nails in different positions.

The frame assembling machine Minigraf 44 can use normal straight V-nails, reinforced V-nails for very hardwood or special V-nails Alfagraf with “pulling power” effect of different sizes.

2.2 MAIN COMPONENTS

The main components constituting the machine are:

- Frontal clamping device to have a perfect joint.
- Brake on position to insert easily intermediate V-nails in any profile
- Pneumatic balancing that allows to work easily when the working bench is tilted.
- Adjustable tilting fences.
- Floor stand
- Magnetic pressure pads of several types, at quick replacement, to have the proper clamping of any profile
- Soft moulding clamp device that adjust the pressure during the several working phases.
- Dual functions foot operating pedal for separate control of clamping and nail insertion
- Pneumatic opening of V-nails magazine for a very quick reloading
- Nail heads sizes 7, 10 and 15 mm.

2.3 MACHINE STRUCTURE

The movement directions during the machine working are the followings:

- X AXIS
Movement of horizontal pressor
- Y AXIS
Movement of vertical clamp



2.4 DIMENSIONS

The overall dimensions are reported on table 2.9-A

2.5 SURROUNDING CONDITIONS

The machine does not need special surrounding conditions. It has to be installed inside an industrial building, lit, aired and with a compact and flat floor. The admitted temperatures go from 5° to 40° C, with an humidity not higher than 50% at 40° C or 90% at 20° C.

2.6 LIGHTING

Premises lighting must be conformed to the norms in force in that Country where the machine is installed and has to guarantee a clear visibility and do not create dangerous situations.

The average quadratic weighed level, according to the acceleration frequency to which arms are exposed does not exceed 2,5 m/s².

2.7 VIBRATIONS

In standard conditions conformed to the indication of machine proper utilization the vibrations do not create dangerous conditions. The average quadratic weighed level, according to the acceleration frequency to which arms are exposed does not exceed 2,5 m/s².

2.8 NOISE EMISSIONS

The machine is designed and projected for reducing the noise emission level to its source. In standard working conditions the Machine noise power level is:

Acoustic Continuous Equivalent weighed pression A	<70dB
Acoustic Istantaneous weighed pression	<130dB

The noise levels indicated are emission levels and are not representing sure operating levels. In spite of existing a relationship among emission levels and exposure ones, this can not be used in a reliable way to define if further cautions are necessary. The factors determining the exposure level to which the working force is subjected, include exposure lasting, working premises characteristics and other noise sources (number of machines, closed proceeds, etc...). Furthermore, also the allowed exposure levels could change according to the several Countries. At any rate, the information provided, will allow the Machine Operator to achieve a better evaluation of danger and risks he is submitted to.



The indicated noise levels are emission ones measured in standard conditions of use. In case of any machine modification, the above mentioned levels could be changed and should be settled directly on the same machine.

2.9 TECHNICAL DATA

Here below are indicated Machine data and technical characteristics to which make reference for any eventual contact with Producer Technical Assistance.

-Frames thickness	min-max	6-70 mm.
-Frames width	min-max	10-120 mm.
-Max distance among V-nails		120 mm.
-V-nails magazine capacity		n. 230
-V-nails size		7, 10, 15 mm.
-V-nails size on request		3, 4, 5, 12 mm.
-Pneumatic supplying		BAR 4-6
-Weight		about 70 kg
-Height of working bench		960 mm.
-Overall dimensions		600x520x1250 mm.

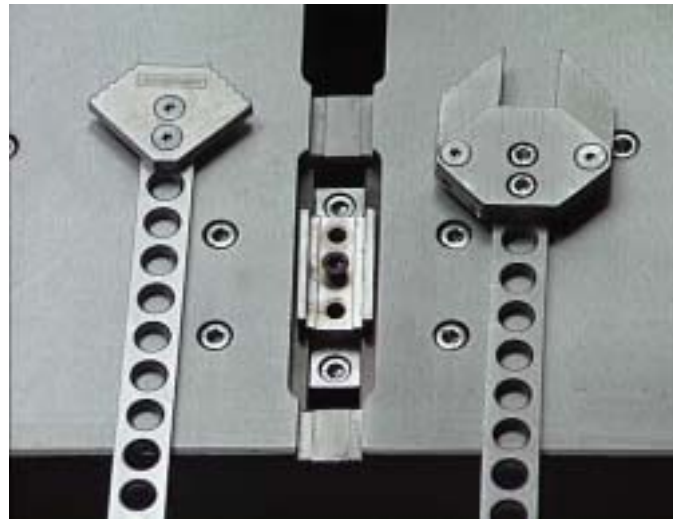

Picture 1

2.10 STANDARD EQUIPMENT

The equipment listed here below is the standard one. Possible special supplying could consequently need different components from the listed ones.

2.10.1 Standard accessories

Once removed the packing, please check the presence of following accessories (in the version equipped with floor stand, the accessories are lodged into the drawer located on the floor stand).

- N.1 nail head mm. 7
- N.1 nail head mm.10
- N.1 nail head mm.15
- N.1 L shaped pressure pad in vulkolan
- Magnetic pressure pad support
- Round felted pressure pad
- N.1 Allen Wrench 5 mm. for V-nails head replacement
- N.1 Brass rod magnet to remove V-nails

2.10.2 Upgrading and implementing of mechanical parts

The machine has been realized following a modular criterion, therefore the existing equipment can be further upgraded with additional accessories that will not alter its basic structure.

Technical upgrades on the machine model, if any, will be such that they can be installed at any time without requiring any substantial modifications to the machine structure.

2.10.3 Optional accessories

- Adjustable tilting fences at 3 knobs
- Wooden working bench extension
- Metallic working bench extension
- Floor stand (only for bench version)
- V-nails claw heads size 3-4-5-12 mm.
- Movable leaf of horizontal clamping (see fig.1)

2.10.4 Customized optional accessories

Thanks to its versatility this machine can be 'custom-made' to meet our users' requirements, with additional accessories that can make frame assembling easier: e.g. special fences for peculiar moulding shapes, special clamps to ensure the mouldings are locked properly during V-nail firing, and so on.

2.11 ELECTROMAGNETIC AMBIENT

The Machine is designed to operate properly in an industrial electromagnetic ambient without altering it being an exclusively pneumatic machine.

3. SAFETY

3.1 GENERAL WARNINGS

The operator must read paying the maximum attention to the information written on this Handbook, expressively about proper precautions for Safety listed in this chapter.

It is indispensable for the operator to follow the warnings listed here below:

- Keep clean and ordered the machine and the working premises
- Provide appropriate containers to stock both just worked pieces and ready to work ones.
- Use the Machine only in normal psycho physical condition
- Wear an adequate clothing to avoid obstacles and/or dangerous entangles to/from the machine
- Wear the individual protection gears prescribed by instructions handbook, regarding the effected operations
- Do not remove or alter the warning plates and adhesive signs
- Do not remove or elude the Machine Safety Systems
- Keep the fingers away from the working area
- Disconnect air pressure supplying during any maintenance intervention
- Keep the feet separated from the pedal during Machine regulation

3.2 SCHEDULED USE

The Machine is designed and built to execute junctions of frames.

The machine is projected for manual use only (under operator control).

3.3 INADVISABLE USE

The machine has not to be used:

- For uses different from those listed in 3.2 paragraph
- In explosive or aggressive atmosphere, at high density of dust or oily substances suspended in the air
- In flammable atmosphere
- Outside in all weather severity
- For working materials not suitable with machine characteristics

3.4 DANGEROUS AREAS

The area of frames leaning is defined “working area”

The dangerous areas of machine, include the movable parts and surrounding zones

Picture 3.4.A- Working area and dangerous zones



3.5 PROTECTION DEVICES

The machine is equipped with adequate protections for persons exposed to the risks due to the transmission mobile elements, or movable organs taking part in working (driver blade, horizontal pressor, vertical clamp).

3.6 STOP FUNCTIONS

The machine stop functions are the following:

- Fast clutch fitting stop (Category 0).
- Foot pedal Stop (Category 1).

STOP CATEGORY 0

It is obtained disconnecting the fast clutch fitting from feeding system (uncontrolled stop).

STOP CATEGORY 1

Controlled stop obtained by lifting the foot from the pneumatic pedal that does not allow the v-nails firing.

3.7 SAFE WORKING PROCEDURES



The machine is projected and realized to eliminate any risk connected with its use. The utilizer is requested to achieve an adequate training to be instructed by Alfamacchine’s technicians.

The other risks related with manual working way, are:

- Finger crushing in the vertical clamp working area
- Finger crushing in the frontal clamp working area

Even if the protection shield is properly adjusted, it is necessary to follow carefully the following instructions:

- 1 Keep the fingers away from frontal and vertical clamp working areas
- 2 Disconnect the air pressure and during any maintenance interventions
- 3 Keep the foot away from the pedal during machine regulation

3.8 RESIDUAL RISKS

During the normal working cycle and while maintenance, the operators are exposed to several residual risks that, because of operations own nature, can not be totally eliminated.

- Risk of finger crushing in the working areas of vertical and frontal clamping

3.9 PLATES

The warning plates carrying out safety functions can not be removed, covered or damaged.

To take vision of plates or adhesive signs location, consult the Fig.10.2-D

Table 3.8 A- Types of plates



Plate concerning machine characteristics



Adhesive sign concerning the fingers crushing located on the protection



Adhesive sign concerning the behaviour to be kept during the working cycle



Adhesive sign concerning the behaviour to be kept during the working cycle

4. INSTALLATION

4.1 SHIPPING AND HANDLING

The shipment must be effected by professionally qualified staff. The machine has to be shipped in a safe way to avoid any damage to its parts.

- All the protections and guard devices must be properly closed and clamped.
- The machine has to be shipped like positioned for installation.
- Before shipment, it is necessary to lubricate the not painted parts to avoid their detriment.
- According to the type of shipment, it is necessary to protect the machine from any jarring impact or stress

Picture 4.1A – machine handling indications

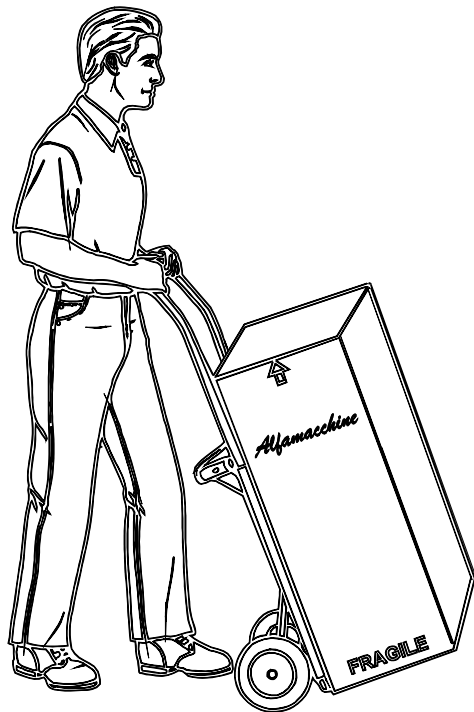

Machine total weight: about 70 Kilos

	<p>The machine lifting must be effected by 2 operators.</p>
--	-------------------------------------------------------------

Any damaging of the machine caused during its shipment or handling is not covered from warranty. Repairs or replacements of damaged parts are charged to the customer.

4.2 STORAGE

In case of long inactivity, the machine must be stored with cautions concerning storage place and times.

- Store the machine indoor
- Protect the machine from jarring impacts and stresses
- Protect the machine from humidity and high thermic excursion
- Avoid the machine could touch corrosive materials
- Lubricate the not painted parts

4.3 PRELIMINARY ARRANGEMENTS

To install the machine it is necessary to prepare a working area adequate to machine dimensions, lifting devices chosen and length of mouldings to be worked.

4.4 UNPACKING

The machine, bench version, is shipped packed into an appropriate carton and protected with foam and polyurethane parts.

Remove the external packing and save it for future use.

Check for any casual shipping damage and report immediately. Shipping damages or any other defects must be reported to *Alfamacchine* within and not later than 8 days from receipt of machine.

4.5 MACHINE POSITIONING (floor stand version)

Position the machine in its own working spot.

Screw the provided 4 little feet to the floor stand and level the machine by releasing or tightening the a.m. feet.

4.6 CONNECTIONS

To avoid any problem during machine starting, it is suggested to follow the instructions listed here below.

4.6.1 PNEUMATIC CONNECTION

Minigraf 44 works by compressed air and is controlled by a foot pedal that allows the activation of frontal clamping and by a joystick that controls the vertical clamping and V-nail firing.

Minigraf 44 (bench model)

Before connecting the machine with the pneumatic system, it is necessary to connect the control foot pedal.

The 3 pipes for compressed air connected with the pedal must be inserted into the 3 fittings located on machine right side in the following sequence:



Picture 2

Upper connection	Red pipe into the red fitting (external side)
Central connection	Black pipe into the black fitting (central fitting)
Lower connection	Transparent pipe into the 3 rd fitting (user side)

Use the supplied fast clutch fitting to connect the air compressed system. You could use also another fitting suitable with your pneumatic system (see fig. 3, 4).



Picture 3



Picture 4

Minigraf 44 (floor stand model)

Screw the supplied manometer in the air filter lubricator placed on the floor stand right side (see fig. 5).

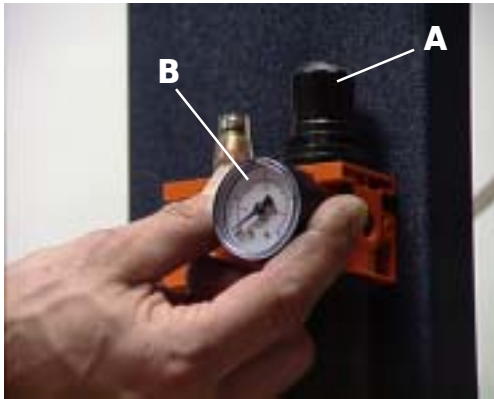

Picture 5

Use the supplied fast clutch fitting to connect the air compressed system. You could use also another fitting suitable with your pneumatic system (see fig. 6 - 7).





Picture 6



Picture 7

	<p>It is advisable the installation of a filter lubricator on the air compressed system to obtain clear and lubricated air. Use only silicone lubricating oil for pneumatic systems. The use of inadequate oil could damage the valves.</p>
-----------------------------------------------------------------------------------	---------------------------------------------------------------------------------------------------------------------------------------------------------------------------------------------------------------------------------------------

	<p>Check that pressure value showed on the pressure dial (B) of the lubricator/reducer filter is between 6 and 8 Bar (see picture 5)</p>
-----------------------------------------------------------------------------------	------------------------------------------------------------------------------------------------------------------------------------------

	<p>DO NOT adjust by using the A regulator of lubricator/reducer filter (see picture 5)</p>
-----------------------------------------------------------------------------------	--------------------------------------------------------------------------------------------

Once connected the machine with the pneumatic system, check the functioning of the 2 positions foot pedal and that of the V-nails firing lever (2 positions control lever).

The proper functioning of the foot pedal is the following:

- when the foot pedal is **PRESSED HALF WAY** it activates the horizontal clamp
- when the foot pedal is pressed **FULL DOWN** it activates the vertical clamp and the positioning brake (optional)

The manual control lever with 2 positions button activates the following commands:

- vertical clamps and respective position B (1st position);
- V-nail firing (2nd position),

4.7 PRELIMINARY CONTROLS

The Machine preliminary operations before the 1st starting, must be executed by a technician appointed from the customer. Before machine commissioning, it is necessary to execute certain verifications and checks to prevent mistakes or accidents during commissioning step.

- Verify that machine has not been damaged during assembly steps.
- Verify with extreme care, the pipes integrity

4.8 MACHINE ARRANGEMENT

4.8.1 V-Nails magazine loading

To load the V-nails magazine proceed as follows:

- Move backward the claw pusher by flipping the special lever located on the right side of the machine working bench to make accessible the V-nails magazine (see fig. 7).
- Insert one or more V-nails sticks, taking care that the sharpened edge of the V-nails (glue side) faces up and that they are loaded with the V of the V-nails pointing in the direction indicated in the figures 8 and 9; on the top of that check the V-nails size is suitable with the type of claw head mounted.
- Move forward the claw pusher by flipping the control lever (see fig.7)



Picture 8



Picture 11

- Take out the V-nail guide head (see fig. 12)



Picture 9



Picture 12

- Move backward the claw pusher by flipping the special lever located on the right side of the machine working bench to make accessible the V-nails magazine (see fig. 8).



Picture 10

4.8.2 V-nail guide head replacement to change V-nails size

The V-nail guide head must be changed each time you use V-nails of different sizes.

Proceed as follows to replace it:

- Loosen the locking screw of the V-nail guide head using the proper 5 mm Allen wrench (the screw is on the opposite side from the V-nails magazine (See fig. 10)



Picture 13

- Remove all the V-nails that are still in the magazine (using the proper brass magnet, if necessary) (see fig.11).
- Insert the new V-nail stick (of desired height) into the magazine
- Move forward the claw pusher by flipping the control lever (see figure 7).
- Insert the new size V-nail guide head to match the V-nails to be used (see fig. 12).
- Tighten the locking screw of the V-nail guide head (see fig.10).



Picture 14

4.9 ADJUSTMENTS

Being the machine completely tested and checked in Alfamacchine's plants before its shipment, the operator has only to effect the following adjustments:

4.9.1 Setting stops for V-nails positioning

The working stroke of the driver blade is adjusted by 2 stop handles positioned on a measurement gauge (see fig.15).

The stop located inside the hand lever (operator side), refers to the V-nails rear position; the located in front of a.m. lever refers to the V-nails external position.

The carriage with the driver blade is positioned by shifting the handle from the eternal position to the rear one.



Picture 15

4.9.2 Vertical clamp adjustment

The vertical clamp position can be adjusted by the side-handle. Proceed as follows to position properly the vertical clamp:

- Loosen the side clamp (see figure 16) by using the handle and adjust the pressure pad height over the frame (it is advisable to adjust an height between 5 and 8 mm to avoid any accidental fingers crushing).
- Tighten the handle once reached the proper position
- Activate the vertical clamp by pressing half way the foot pedal and then the control button or pressing full down the full pedal.
- Check that the mouldings to be assembled are properly clamped.

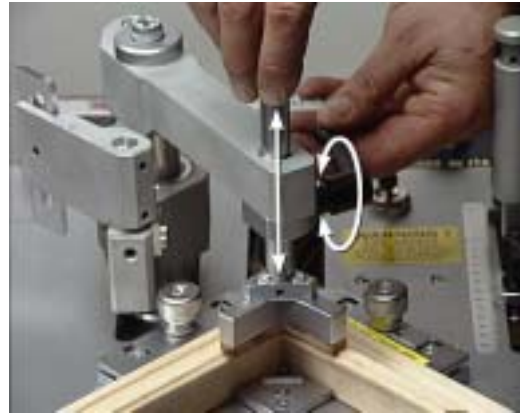

Picture 16

4.9.3 Horizontal clamp adjustment

The Frontal Clamp (horizontal clamp) has a series of holes in the flat bar (see Pict. #8) that lock into a peg in the front channel. Lift the bar to take it out of its initial position and make it move forward and backward.

To lock the bar it is sufficient to insert it into the proper peg located at the centre of the guide channel.

Proceed as follows to position the Horizontal Clamp correctly:

1. Remove the bar from the peg (lifting it by about 10-15 mm) and move it forward up to reach the mouldings to be assembled;
2. Lower the bar to allow the insertion of tracking screw and the locking in the next position.



Picture 17



TAKE CARE: In case of continued use without needing to remove the pierced bar from its position, it is possible to fix it into the peg using the proper screw. During machine transport, it is advisable to fix the bar using the supplied knob.

4.9.4 Fences adjustment

The Minigraf 44 is equipped with a fence composed by two separate parts.

Each part of the fence (right and left) is equipped with a knob that allows the tilting of supports.

The use of this fence is suggested for working frames with irregularities or little cambers on the external side.

If once the frontal clamping is inserted, the combining of the mitres is not perfect, the tilting fence can compensate such a fault.

The Minigraf 44 for 90° (4 sided frames), 120° (6 sided frames) or 135° (8 sided frames) junctions setting properly the two fence supports (see fig. 18-19-20).

To modify the position of the two fence supports, proceed as follows:

- Remove the external screw by using the 5 mm Allen wrench
- Release the internal screw and shift the fence up to reach the holes located on the working bench

The exact position of fence supports can be obtained with the help of a special fence.

Make sure that the 120° or 135° angle formed by the two supports is exactly centered on the internal vertex of V-nails claw head.



Picture 18



Picture 19



Picture 20

4.9.5 Protective shield adjustment

The machine is equipped with a protective shield (see fig. 21) made of transparent plastic material, to avoid the operator accidental fingers crushing.

Proceed as follows to adjust the protection shield:

- 1 position the mouldings to be assembled on the working bench
- 2 loosen the screw shaped handle fixing the protection and lift or lower it at an height of about 6-8 mm from mouldings to be assembled;
- 3 tighten the screw shaped handle to lock the protection shield.



Picture 21



The protection shield opening, effected by its overturning, causes the control pedal deactivation.

4.9.6 Working pressure

The working pressure must be adjusted to the hardness of mouldings to be assembled.

The pressure regulation allows to change the clamping pressure of mouldings to be assembled.

A too high working pressure can cause a poor junction and (especially on small-size frames) the mouldings crushing.

A too low working pressure can cause an incomplete insertion of V-nail into the frame.

The working pressure is adjusted by means of the regulator on the panel near the manometer R₁ (see fig.22)



Picture 22

1. pull up the regulator cap by 3÷4 mm to unlock position
2. turn clockwise to increase the pressure and counter-clockwise to decrease it.
3. push the regulator cap back down, to lock into position



DO NOT ADJUST the pressure if the machine is not power supplied.

The suggested pressures are:

Soft woods	(samba,.....)	1.5 - 2.0 Bar
Medium	(ramin,.....)	2.0 - 3.0 Bar
Very hard woods	(oak)	3.0 - 5.0 Bar

The above listed values apply to 7 and 10 mm high V-nails. Increase the pressure by 10 % for 15 mm high V-nails.

When stacking 2 or more V-nails, increase the working pressure by 10/15 %.

The Minigraf 44 is equipped with two additional air regulators: R₂ and R₃ (see fig.23-24) that adjust respectively the claw pusher pressure and the ballast cylinder pressure when working with the machine in tilted position.



Picture 23



Picture 24

The claw pusher pressure (R₂) must be set at 1.8-2.0 bar. If this pressure is too high, it could cause the simultaneous firing of 2 V-nails. On the contrary, a too low pressure, could cause a misfeed and not continuative V-nails firing.

Adjust the R3 regulator, as described for R2, to reach the optimal pressure.



Take care: the claw pusher control lever must be closed during the R2 adjustment.

In order to allow an easy use of the machine tilted back, it is equipped of a ballast cylinder with a regulator (R3) and a surge tank (located on the floor stand) that provides an air cushion to balance the weight of internal components when the machine is tilted back.

To obtain an optional regular balancing, set the pressure at:

- 0 BAR, when the machine is flat
- 1,0÷1,2 BAR, when the machine's tilted



After operating with the machine tilted back, set the balancing pressure to 0 before going back to the flat position.

4.10 CHECKING OPERATIONS TO BE EFFECTED BEFORE WORKING START

Once the machine has been properly installed (like previously described), check that:

- The mouldings to be assembled are properly positioned on the working bench
- The magazine is loaded with the type suitable with the mouldings to be assembled
- The adjustment of vertical and horizontal clamping is correct (chapter 4.9.2 and 4.9.3)

TAKE CARE: to improve the clamping of very shaped profile, big sized o very hard moulding it is possible to use instead of standard pressure pad, a felted pressing pad provided on the magnetic support in order to obtain the best clamping.

- The protective shield is properly positioned (see chapter 4.9.5)
- The working pressure is adequate to the wood hardness (see chapter 4.9.6)



If you want to insert 2 or more V-nails one upon the other in the same position, you must release the pedal until half stroke and then press it again full down to insert the second V-nail

5. FUNCTIONING

5.1 OPERATORS

The machine has been projected to be used by only one operator.

The staff assigned to operate with the machine, must be in possession (or acquire through an adequate training) the requirements indicated here below, and, in addition, to have the knowledge of this handbook and of every information concerning safety:

- General and technical culture sufficient to comprehend this handbook contents and understand properly drawings and schemes
- Knowledge of main sanitary, technological and anti-accidental norms
- Overall knowledge of line and plant where is inserted the machine
- Specific experience frames assembly working technologies
- To know how operate in case of emergency, where to find the individual protection means and how to use them properly.

The Maintenance Men, in addition to the above mentioned characteristics, must be in possession of an adequate technical education.

5.2 FUNCTIONING DESCRIPTION

The machine has only one possible operating way:

- manual mechanic functioning by using the pneumatic foot pedal and the manual joystick.

Pressing the foot pedal half way the frontal clamp is activated. Press the foot pedal full down the vertical clamp is activated. The joystick allows the shift of positioning of V-nails firing group. According to the use of the foot pedal, the joystick allows several operations:

If the foot pedal is pressed half way down:

- pressing the button half way, the vertical clamp is activated
- pressing the button full down, the V-nail is fired.

If the foot pedal is pressed full down:

- pressing the button the V-nail is fired

To make a junction, the operator must proceed as follows:

1. position the mouldings to be assembled on the machine working bench
2. set the insertion limits
3. press the foot pedal half way down to activate the frontal clamp
4. shift the joystick on the 1st inserting point
5. press the button half way (or the foot pedal full down) to activate the vertical clamp
6. press the button full down to insert the V-nail

Take care: if you want to stack 2 or more V-nails in the same position, you must release the button up to half way and then press again it full down to insert the 2nd V-nail and so on.

7. release the button (or the foot pedal) half way to rearm the driver blade and release the brake on position
8. shift the joystick in the next inserting point
9. repeat the steps 5, 6, 7 and 8.

When working with big sized frames, on the machine (floor stand version), can be mounted a wooden extension of the working bench, and it can work in tilted position.

Usually, when the machine is tilted back, the operator working position is opposite to the normal one.

To tilt back the machine, operate as follows:

- loosen the handle located on floor stand right side (fig. 25)
- tilt the machine up to reach the desired angle (fig. 26)
- tighten the handle to lock the machine in position.

Make reference to the chapter 4.8.6. for pneumatic balancing of V-nails firing group.



Picture 25



Picture 26

5.3 TIPS FOR PERFECT JUNCTIONS

a) V-nail types

In order to allow the machine to make excellent quality junctions using different materials, it has been necessary to manufacture different V-nails types for different uses (see attachment D).

V-nails can be classified in three different groups:

for soft woods and soft plastic	Suggested V-nails code	SW
for medium woods	Suggested V-nails code	MW
for hard woods	Suggested V-nails code	HW

b) Assembling positions

It is advisable to operate as follows in order to achieve the best results in terms of junction quality:

Never drive V-nails near the junction vertex. The minimum recommended distance from the external vertex is at least 10 mm.

When you want to make the junction using only one V-nail, the most suitable position is in the middle of the moulding (see fig. 21)

In case you want to insert 2 or more V-nails into each junction, we recommend you to insert the most external one 1/3 from the external vertex and the most internal one 1/4 from the internal vertex.

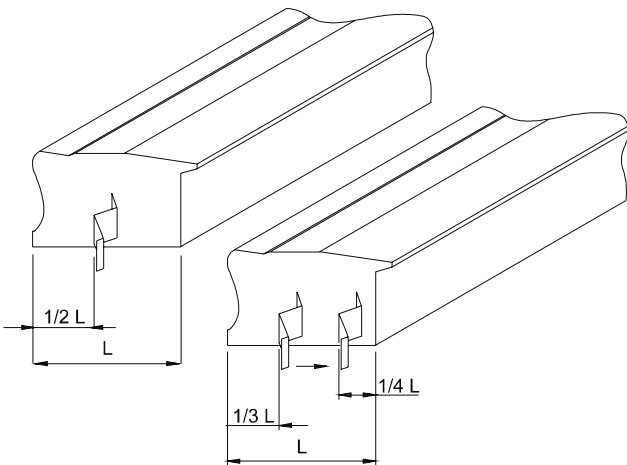

Picture 27

5.4 MACHINE STOP

The machine can work only by pressing the pneumatic foot pedal; to stop it is enough to lift the foot from the pedal.

It is possible also to disconnect the fast clutch fitting from the compressed air.

5.5 MACHINE REINSTATEMENT

The machine reinstatement is effected by pressing the pneumatic foot pedal.

5.6 PUTTING OUT OF SERVICE

In case on long inactivity periods it is necessary to disconnect the fast clutch fitting from pneumatic system and the power supply cable.

6. MAINTENANCE

6.1 STATE OF MAINTENANCE

The maintenance operations must be effected with the machine in the conditions described at the voice “state of the machine” in the tables 6.6.A and 6.7.A

6.2 MACHINE ISOLATION

Before effecting any type of maintenance or repair , it is necessary to isolate the machine from supplying sources, making the following operations:

- 1) Disconnect the fast clutch fitting from the pneumatic system.

Once finished the intervention, before reactivate the pneumatic supplying, ascertain that any component and any pneumatic connection are properly reinstalled.

6.3 SPECIAL CAUTIONS

During the maintenance or repair operations is suggested to proceed as follows:

- Before starting any operation place a sign-board “machine under maintenance” in a well visible position
- Do not use solvents or flammable materials
- Do not step on the machine parts, because they have not been projected to sustain the weight of persons.
- Disconnect the power supply from the electric system
- Once all the operations are finished, restore and place properly the protections and shields removed or opened

6.4 CLEANING

The machine structure is simple and robust therefore the mechanical parts do not require any special maintenance.

It is advisable to follow the rules listed here below:

- Regularly remove glue or other residues from the V-nail head and from the upper part of the driver blade;
- always keep clean and without residues the V-nails magazine
- remove any residues from the V-nails guide “L” shaped support.

Do not use water to clean the machine, otherwise metallic parts may oxidise.

	<p>Before effecting any cleaning intervention, the operator must disconnect the pneumatic system..</p>
-------------------------------------------------------------------------------------	--------------------------------------------------------------------------------------------------------

6.5 LUBRICATION

Use preferably CASTROL MAGNA GC 32 or equivalent oil

Furthermore, we recommend to lubricate the driver blade every 200 working hours.



Unsuitable lubricants may cause valve seal problems (seals may become too large) and consequent Valve jamming.

6.6 ORDINARY MAINTENANCE

The following operations must be executed on times indicated here below. The not observance of following instructions exonerate the Producer from any responsibility regarding the warranty.

The operations described here below, even if simple, must be executed by qualified personnel.

The scheduled ordinary maintenance includes overhauls, checks and interventions that, to prevent stops and breakdowns, keep under systematic control:

- Lubrication state of the machine
- Wear and tear parts state

TAB 6.6 A

MAINTENANCE	DESCRIPTION	MACHINE STATE
V-nail driver blade	Replacement every 1.000.000 V-nails shot	Isolation for maintenance
Movable parts lubrication	Lubricate the driver blade every 200 working hours	Isolation for maintenance
V-nails claw heads	Replacement every 5.000.000 V-nails shot	Isolation for maintenance
“L” shaped supports (V-nails guide)	Replacement every 5.000.000 V-nails shot	Isolation for maintenance

6.7 EXTRAORDINARY MAINTENANCE

Here below are listed the operations that need the intervention of Alfamacchine’s Technical Assistance (see the paragraph 1.2) or by qualified staff authorized by the Producer

The extraordinary maintenance includes interventions to be effected in exceptional cases:

- Breakage
- Revisions

TAB. 6.7 A

MAINTENANCE	DESCRIPTION	MACHINE STATE
Valves and Reducers	Suggested replacement every 6/8 million of V-nails shot	Isolation for maintenance
Frontal and vertical clamping gaskets	Replacement in case of leak of air	Isolation for maintenance

7. DIAGNOSTIC

7.1 SAFETY WARNINGS

The interventions must be executed by personnel properly learned and must be taken all cautions in order to avoid accidental starts.

7.2 TROUBLESHOOTING

TABLE 7.2 - A

TROUBLE	POSSIBLE CAUSE	REMEDY
Pressing the foot pedal the V-nails ejection is irregular	Insufficient working pressure	Check that the minimum value indicated from main manometer is higher than 3 Bar
Pressing the foot pedal the V-nails ejection is irregular	V-nails wrongly positioned into the magazine	<ul style="list-style-type: none"> - Check that the V-nails sharpened side (glue side) faces up - Check that V-nails V vertex is pointing toward machine's external side - Check that V-nails have not glue faults or irregular profiles....in case, replace them
Pressing the foot pedal the V-nails ejection is irregular	Guide channels damaged or jammed	- Check that the guide channels are not dirty or jammed
Pressing the foot pedal the V-nails ejection is irregular	Claw pusher insufficient thrust	Check that the pressure of the reducer feeding the claw pusher cylinder is at least 2 Bar. If necessary, increase it of 10%.
Pressing the foot pedal the V-nails ejection is irregular	Claw head not suitable with V-nails size	Check that the number engraved on the v-nail claw head match up the V-nails size
Pressing the foot pedal the V-nails ejection is irregular	Faulty V-nails	<ul style="list-style-type: none"> - Replace the V-nails - Use shorter sticks of V-nails
Pressing the foot pedal the V-nails ejection is irregular	Insufficient working pressure	Check that the air pressure coming out from the compressor is at least 3 Bars.
Pressing the foot pedal the V-nails ejection is irregular	Opened V-nails magazine	Close the magazine by means of the special lever
Pressing the foot pedal the V-nails ejection is irregular	Faulty valves	<ul style="list-style-type: none"> - Replace the foot pedal valve - Replace the control valves
Pressing the foot pedal for several times the machine's working that was correct at the beginning becomes irregular later	Jammed valves because of surplus of oil or condensation	-Remove the surplus of oil and condensation from the valves disconnecting one by one the control pipes -making to come out the air
Pressing the foot pedal the working pressure indicated on the manometer deeply decreases	Faulty pressure regulator	-Replace the regulator
Pressing the foot pedal the working pressure indicated on the manometer deeply decreases	Feeding pipe too long or of inadequate diameter	Replace the piping with a new one of bigger diameter

TROUBLE	POSSIBLE CAUSE	REMEDY
Pressing the foot pedal the machine works properly, but once the pedal is released you can note a certain delay in re-positioning of driver blade and/or vertical clamp cylinders	Faulty or jammed valves	- Remove the surplus of oil and/or condensation - Replace the foot pedal valve - Replace the faulty control valves
Wishing to insert several V-nails one upon the other in the same point, they do not stack properly or tilt during their insertion	Unsuitable V-nails	Replace the V-nail with suitable ones
Wishing to insert several V-nails one upon the other in the same point, they do not stack properly or tilt during their insertion	Poor frames clamping (the frame moves during the V-nail insertion)	- Check and in case replace the vertical and frontal clamping positions
Wishing to insert several V-nails one upon the other in the same point, they do not stack properly or tilt during their insertion	Wore and torn driver blade	Replace the driver blade
Wishing to insert several V-nails one upon the other in the same point, they do not stack properly or tilt during their insertion	Jammed driver blade	Clean the driver blade upper part removing any material jamming the upper profile
When working in horizontal position the carriage tends to slide toward the upper stop and pulling the control lever toward the lower stop it is stiff.	Fed ballast cylinder	Operate on R3 reducer and set pressure at 0 Bar

7.3 REQUEST OF ASSISTANCE

For any information regarding Use, Maintenance, Installation, etc.. the Producer remains at disposal of Customer requests. The Customer has to formulate clearly the questions sending by fax a detailed description of troubles met. For eventual explanations we specify to make reference to this handbook and to the instructions listed in the paragraph 1.2.

E_Mail: info@alfamacchine.com
FAX: +39-0543-480770
via Dell'Artigiano, 12 - 47100 Forlì - Italy

8. SPARE PARTS

8.1 SPARE PARTS LIST

Even if the machine has been submitted to several tests and functional checks, we list here below the components that we suggest to have a minimum and sufficient set of spare parts to guarantee possible MACHINE STANDSTILL as short as possible.

TABLE 8.1 - A

COMPONENT
<ul style="list-style-type: none">• V-NAILS DRIVER BLADE• V-NAILS CLAW HEADS “L”• SHAPED SUPPORT (V-NAILS GUIDE)• VALVES-REDUCERS-REGULATORS• VERTICAL AND HORIZONTAL CLAMPING GASKETS

8.2 SPARE PARTS ORDERING

We remind you that only a qualified technician can repair the machine.

Thus, we suggest the intervention of Alfamacchine’s Center of Technical Assistance, which is disposable with qualified staff, proper equipment and tools, and with original spare parts.

To order the above listed spare parts, send by fax/letter/Email the following data:

- Model of the Machine
- Code of mechanic exploded drawing
- Reference number of spare part or group indicated on the mechanic drawing
- Code number of single or group spare part

9 DEMOLITION

9.1 DEMOLITION

At the act of demolition it is necessary to separate the parts in plastic material from electric components, that must be send to differentiate gatherings respecting the current Norms.

Concerning the machine metallic mass, it is enough the subdivision between the steel parts and those of other metals or alloys, for a proper recycling by smelting.

10. ATTACHMENTS

10.1 DECLARATIONS

You can find here attached the following declarations

- Declaration of conformity to the Norm 89/392/CEE

10.2 SCHEMES

You can find here attached the following schemes:

- (A) Mechanic Schemes
- (B) Pneumatic Scheme
- (C) Plates Dislocation
- (D) Sharpening Table

SCHEME A - Mechanic Schemes (cod. DWG n° 004.0110)

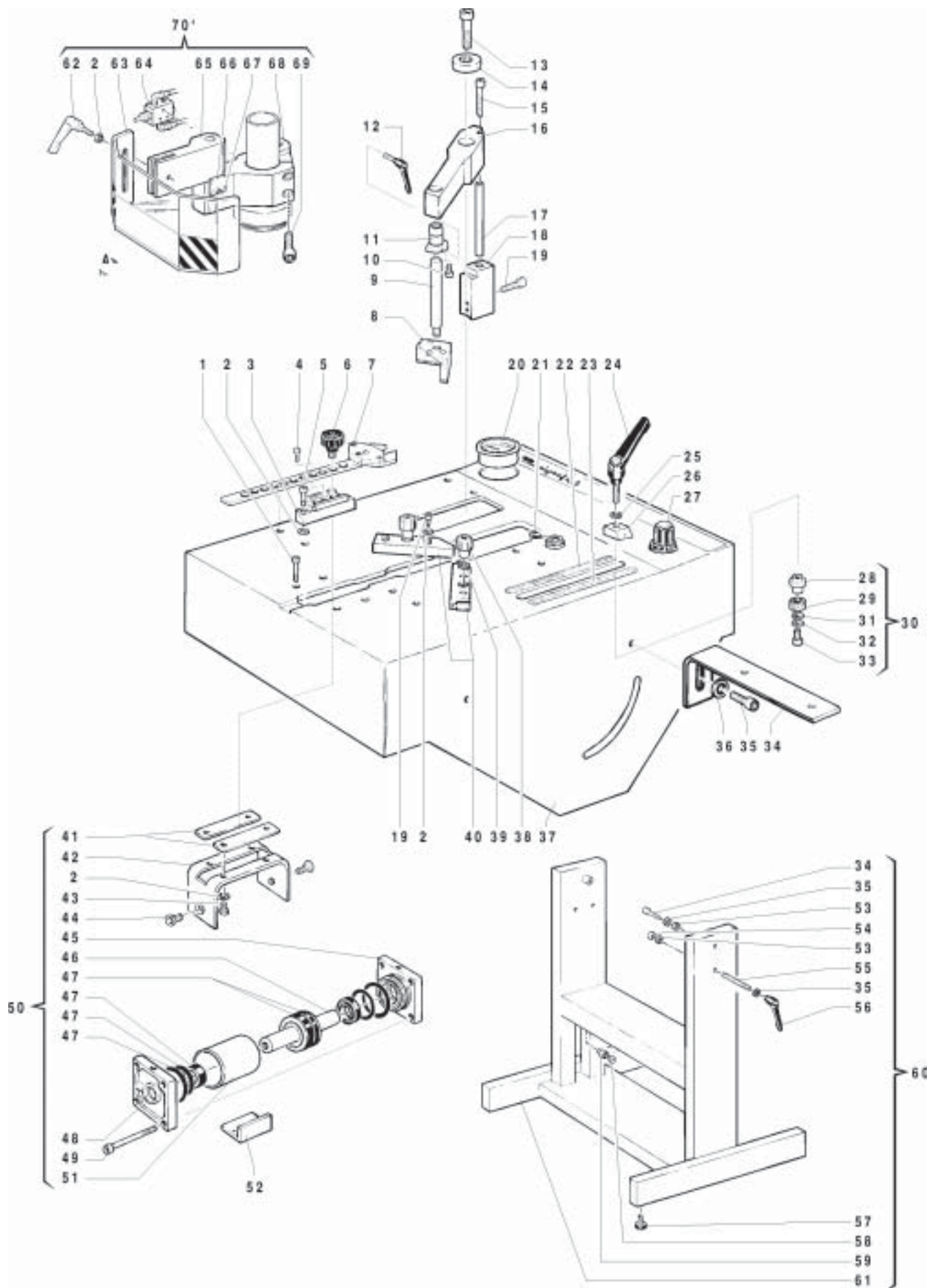

Ref. Description

1	Screw	59	Extension
2	Washer	60	Complete frame
3	Cursor	61	Main frame
4	Screw	62	Knob
5	Screw	63	Protection
6	Knob	64	Valve
7	Rod	65	Support
8	Pressure plate	66	Plate
9	Rod	67	Screw
10	Screw	68	Support
11	Bushing	69	Screw
12	Handle	70	Protection unit
13	Screw	71	Screw
14	Washer	72	Complete cylinder-compression
15	Screw	73	Complete pin
16	Support	74	Stapples pusher
17	Rod	75	Loader
18	Slide	76	Screw
19	Screw	77	Head H7
20	Pressure gauge	77	Head H10
21	Lever-valve	77	Head H15
22	Left inch rule	78	Screw
23	Right inch rule	79	Screw
24	Handle	80	Complete head
25	Washer	81	L Block
26	Index	82	Block
27	Pressure regulator	83	Washer
28	Bushing	84	Screw
29	Spacer	86	Support
30	Complete limit stop	88	Plate
31	Washer	89	Head
32	Grower	90	Gasket Kit
33	Screw	91	Piston and driver blade
34	Bracket	92	Head
35	Screw	93	Support
36	Washer	94	Cover
37	Casing	95	Spring
38	Knob	96	Gasket Kit
39	Washer	97	Screw
40	Complete connecting plate	98	Piston
41	Slide	99	Support
42	Support	100	Brake M44
43	Screw	101	Screw
44	Screw	102	Spring
45	Head	103	Screw
46	Piston	104	Screw
47	Gasket Kit	105	Washer
48	Head	106	Washer
49	Screw	107	Support
50	Complete cylinder	108	Washer
51	Cylinder	109	Bushing
52	Bracket	110	Complete cylinder-compression
53	Spacer	111	Head
54	Retainer	112	Piston
55	Headless screw	113	Gasket Kit
56	Handle	114	Cylinder
57	Foot	115	Head
58	Plug	116	Screw
		117	Screw
		118	Washer

Minigraf 44

- 119 Bottom
- 120 Complete cylinder-compression
- 121 Gasket Kit
- 122 Cylinder
- 123 Piston
- 124 Head
- 125 Rod
- 126 Headless screw
- 127 Support
- 128 Spacer
- 129 Support
- 129 Plate
- 130 Rod
- 131 Support
- 132 Headless screw
- 133 Pushbutton
- 134 Bushing
- 135 Pin
- 136 Bracket
- 137 Screw
- 138 Stem
- 139 Valve
- 140 STG Pushbutton
- 141 Screw
- 142 Screw

SCHEME B - Pneumatic Scheme

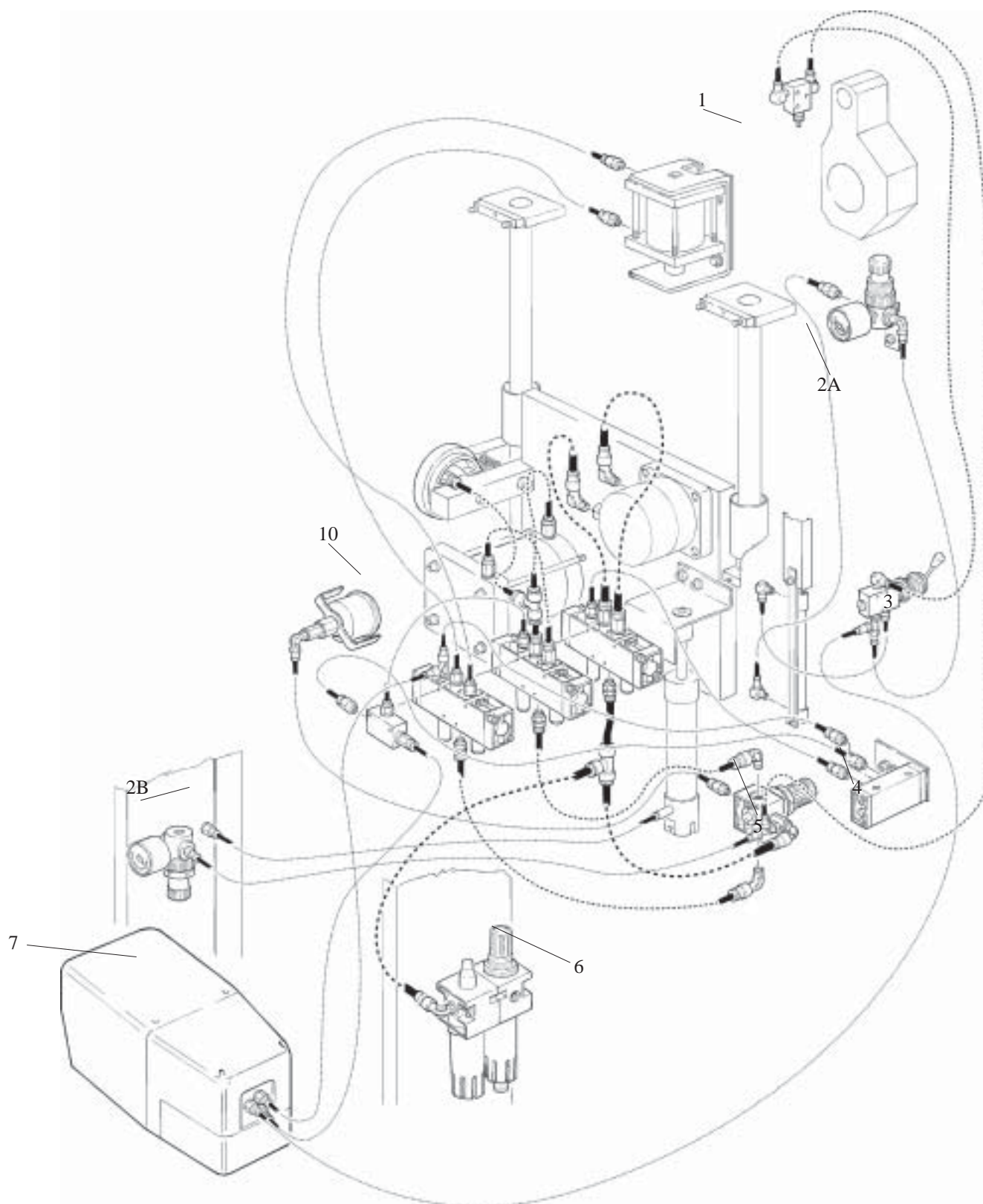
**Ref. Description**

1	Microvalve	6	Filter Lubrificator
2A	Pressure Regulator	7	Foot pedal
2B	Pressure Regulator	8	Valve 60418
3	Lever-Valve	9A	Valve 858/2.52.1.6 (or 2411520016)
4	Valve 0ALF 105	9B	Valve 858/2.52.1.6 (or 2411520016)
5	Pressure Regulator	9C	Valve 858/2.52.1.6 (or 2411520016)
		10	Manometer

SCHEME C - Plates Dislocation

CAUTION: KEEP THE FINGERS AWAY

CAUTION!
FOR YOUR SECURITY
DISCONNECT THE AIR
SUPPLY BEFORE REPLACING
THE V-NAIL CLAW HEAD OR
ANY MAINTENANCE OPERATION

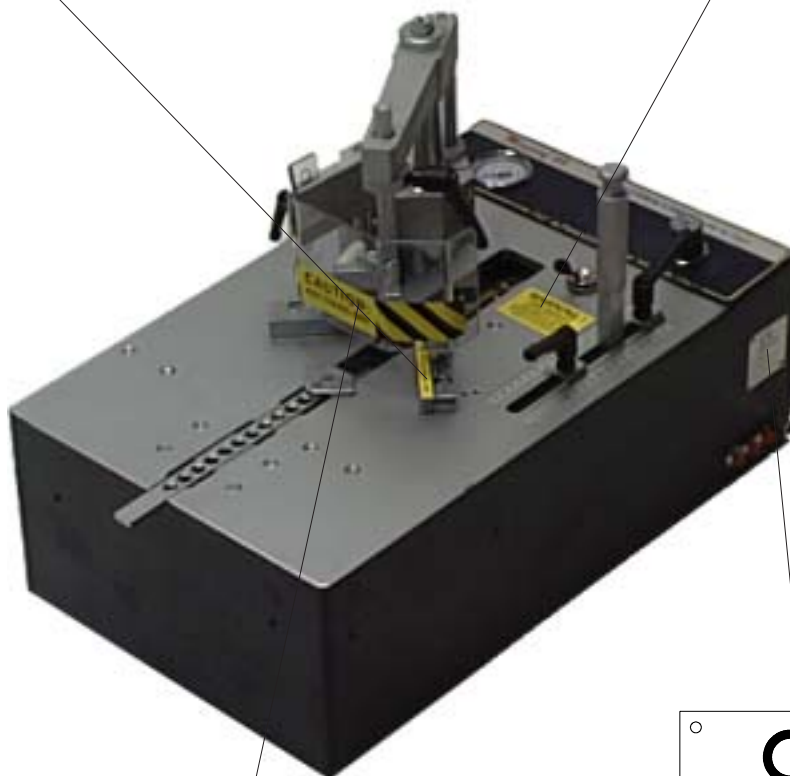

○ **CE** ○
Alfamacchine
Via dell'Artigiano, 12 Forlì ITALY
Tipo Minigraf 44
Anno di costruzione 1998
Matricola 35067
Peso 74 Kg.
Alimentazione pneumatica 5-7 BAR
○

CAUTION:
KEEP FINGERS AWAY

SCHEMES D - Sharpening Table

	SOFT WOOD			HARD WOOD		
	A	B	C	D	E	F
<i>Height</i> mm	Very soft wood	Soft wood	Averaged soft wood	Averaged hard wood	Hard wood	Very hard wood
H 3* mm	◇	◇	◇	MW	MW	MW
H 5* mm	MW	MW	MW	MW	MW	MW
H 7 mm	SW	SW	MW	MW	HW	HW
H 10 mm	SW	SW	MW	MW	HW	HW
H 12 mm	SW	SW	MW	HW	HW	HW
H 15 mm	SW	SW	MW	HW	HW	HW

* V-nails available only on customer's request for order higher than 500.000 pcs.

SW Suitable for soft wood such as: Thailand and Asian South-East wood, Cedar, Pine, Bass, Banak, Obeche, Poplar
Other materials: Cellular, Polystyrene, Vertical Grain MDF

SW Suitable for soft wood such as: Thailand and Asian South-East wood, Cedar, Pine, Bass, Banak, Obeche, Poplar
Other materials: Vertical Grain MDF

MW Suitable for soft wood such as: Cedar, Cherry, Oak, Ramin, Poplar, Maple, Pine
Other materials: Vertical grain MDF, Polystyrene, PVC

HW Suitable for soft wood such as: Oak, Ash, Hickory, Pecan, Maple, Cherry, Ramin
Other materials: Horizontal grain MDF



In order to stack 2 or more V-nails per junction, use V-nails coded **MW** or lower.